

Modu-licious #6

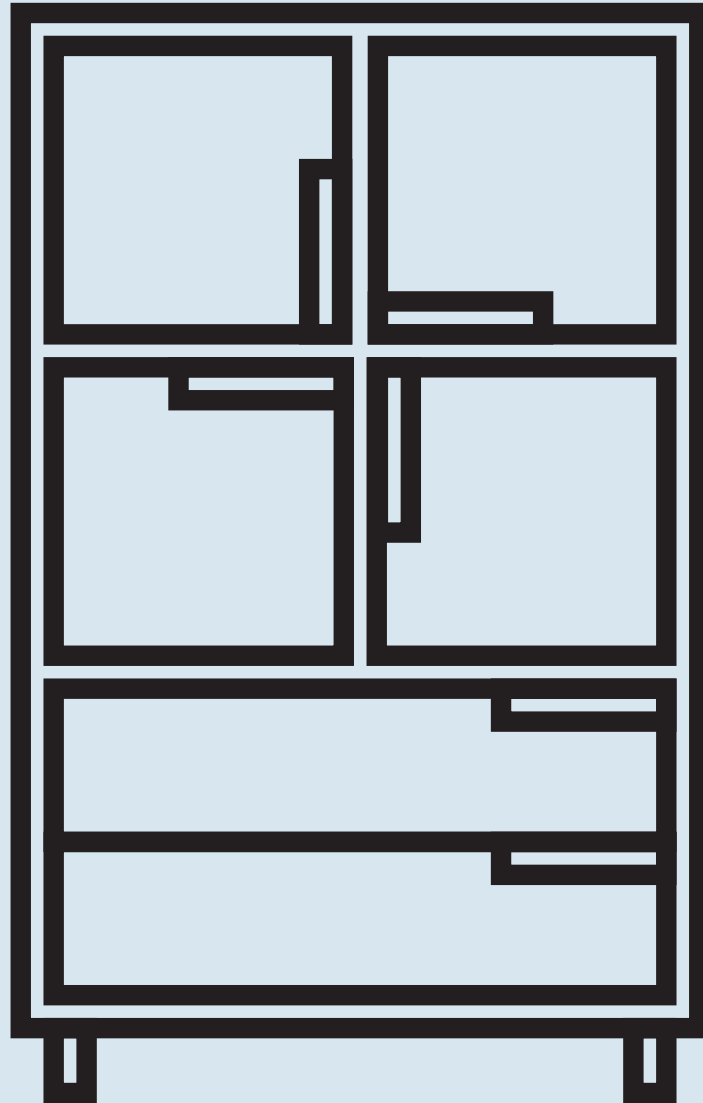

DESIGNED IN 1999

ASSEMBLY NOTES | REV 00



YOU WANT CHOICES, WE GOT CHOICES.

Drawers and doors are your canvas with the award-winning Modu-licious series.

NEED A HAND?

Contact us at service@bludot.com or **844.425.8368** for assistance.

Parts & Hardware



QTY 32

Pt. 5005



QTY 30

Pt. 5002



QTY 30

Pt. 5001



QTY 4

Pt. 8016

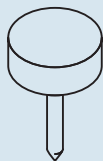

QTY 4

Pt. 4005

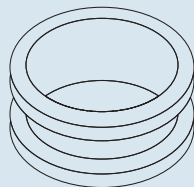

QTY 6

Pt. 8018



QTY 4

Pt. 8015



QTY 12

Pt. 1206

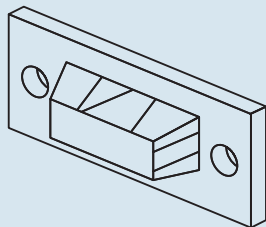

QTY 2

Pt. 8041

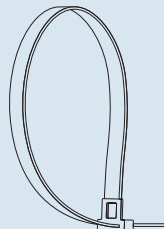

QTY 1

Pt. 8042



QTY 4

Pt. 8014



QTY 4

Pt. 8017

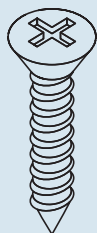

QTY 2

Pt. 1217

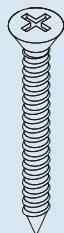

QTY 2

Pt. 1218

Parts & Hardware



QTY 8

Pt. 1023

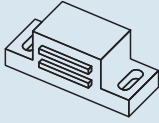

QTY 4

Pt. 8045

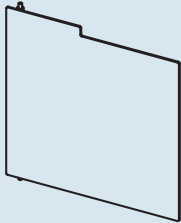

QTY 4

Door

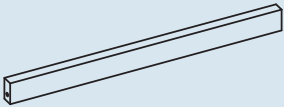

QTY 1

Stretcher

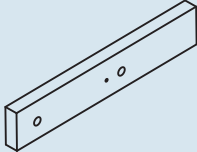

QTY 2

Foot

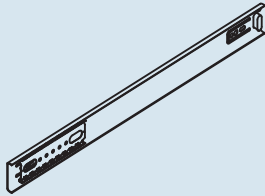

QTY 4

Drawer Slide

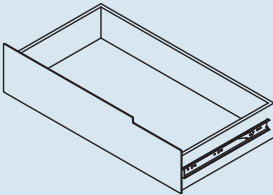

QTY 2

Drawer

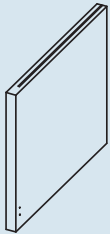

QTY 2

Vertical Divider

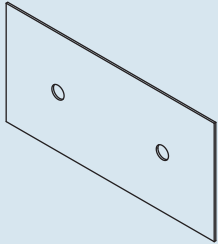

QTY 3

Back Panel

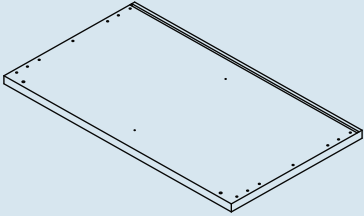

QTY 1

Top Panel

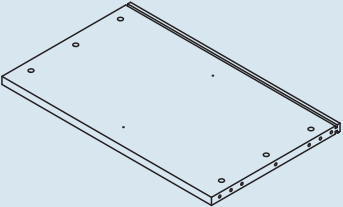

QTY 2

Partition Panel

*panel has grooves on both sides

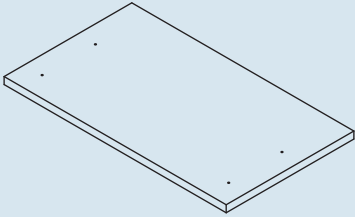

QTY 1

Bottom Panel

*panel has drilled holes on both sides

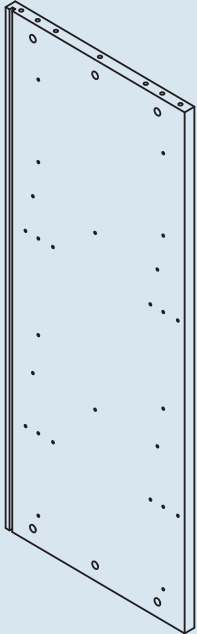

QTY 2

Side Panel

How to use the cam lock system

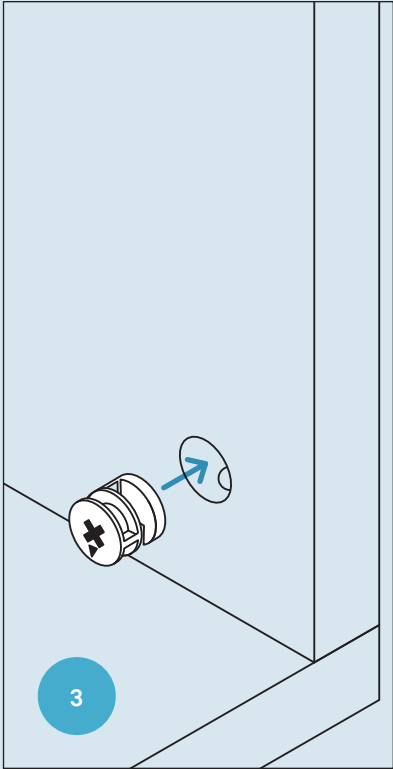
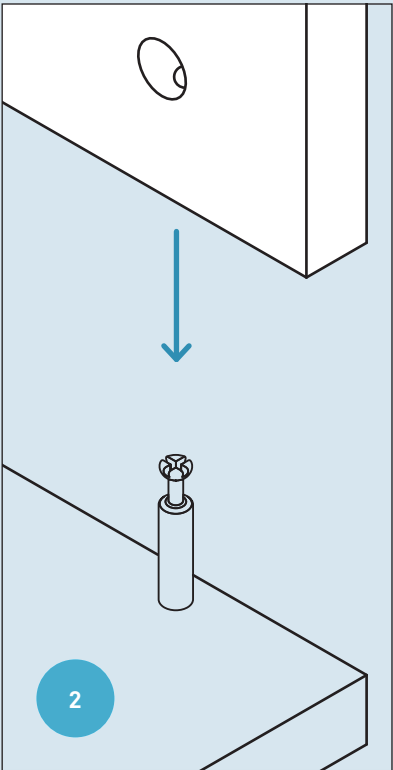
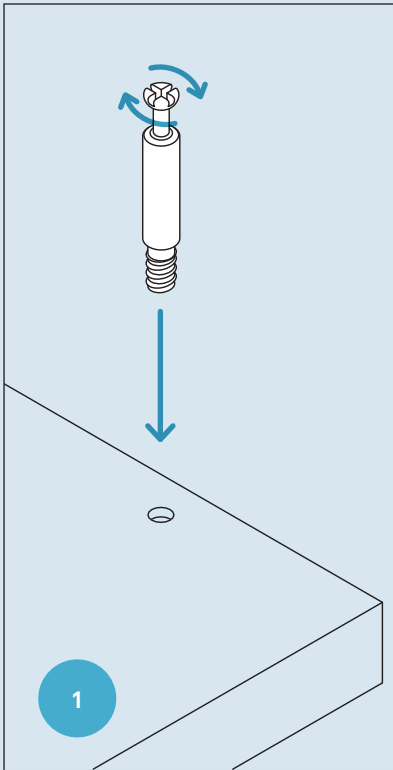

Note direction of cam arrow.

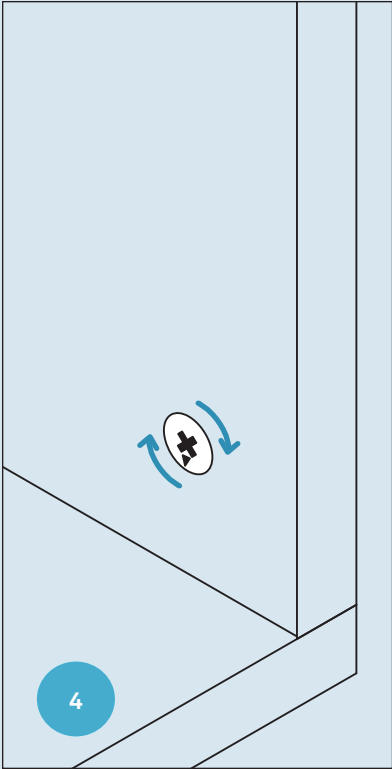

Turn cam clockwise 1/2 turn or until tight.

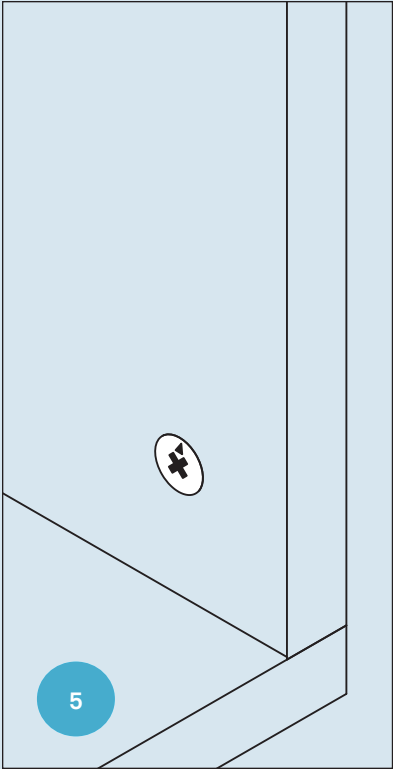

Note direction of cam arrow.

Step 01

ASSEMBLE BASE.

Using the stretcher and feet assemble the base as shown. Refer to page 3 on how to use the cam lock system.

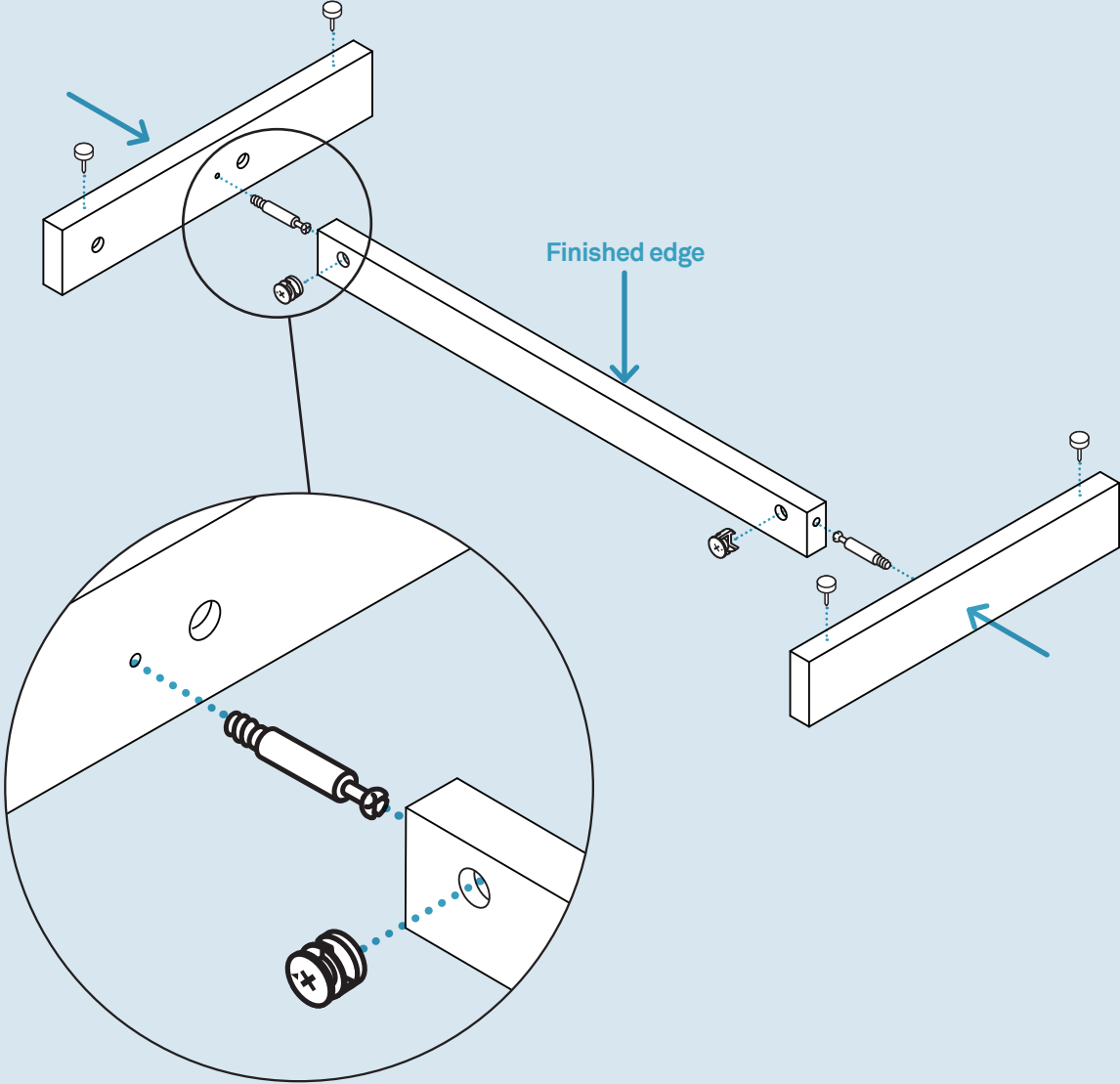

PT. 5001 x 2 PT. 5002 x 2 PT. 4005 x 4

Step 02

ATTACH BOTTOM PANEL.

Attach the bottom panel to the base using the provided hardware as shown. Refer to page 3 on how to use the cam lock system.

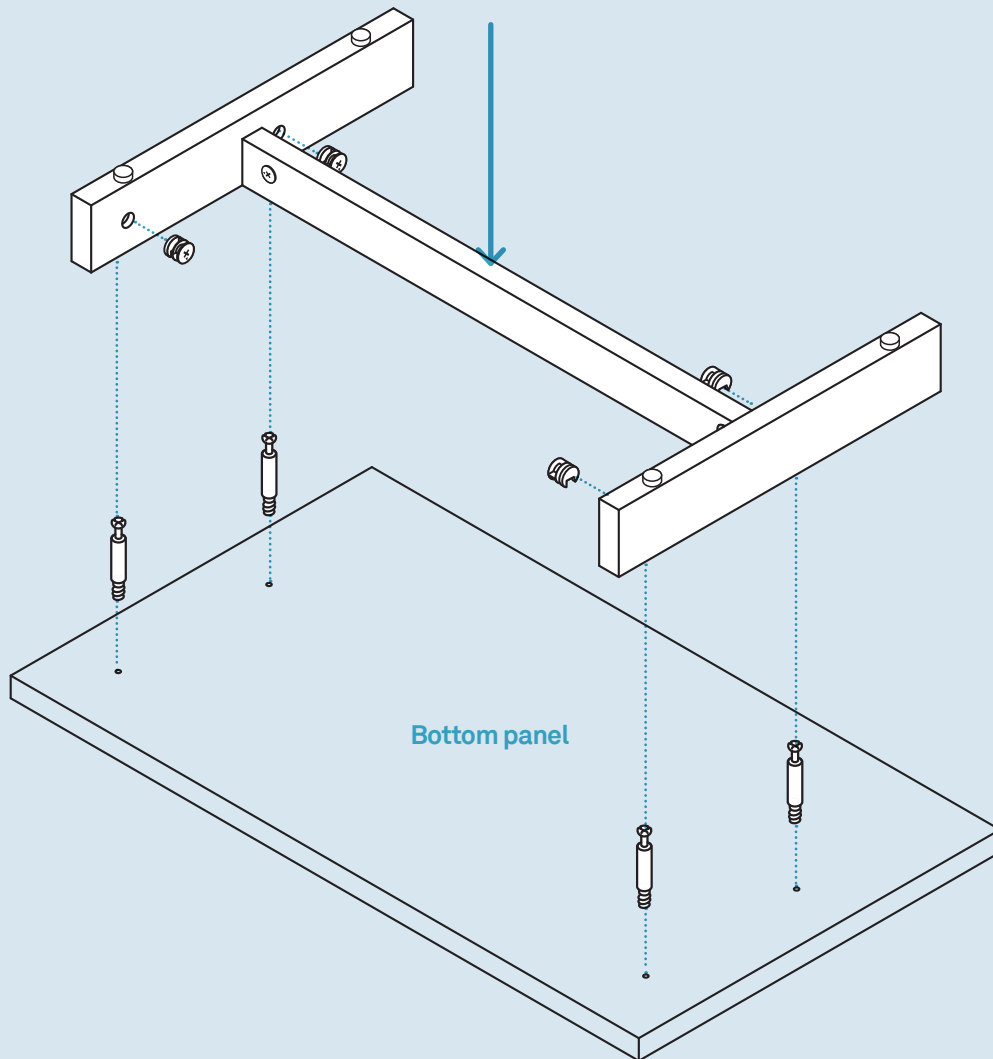

PT. 5001 x 4



PT. 5002 x 4

Step 03

ATTACH DRAWER SLIDES.

Attach drawer slides to side panels as shown using the provided hardware. Repeat for left side panel.

Right side panel

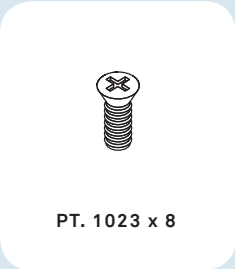
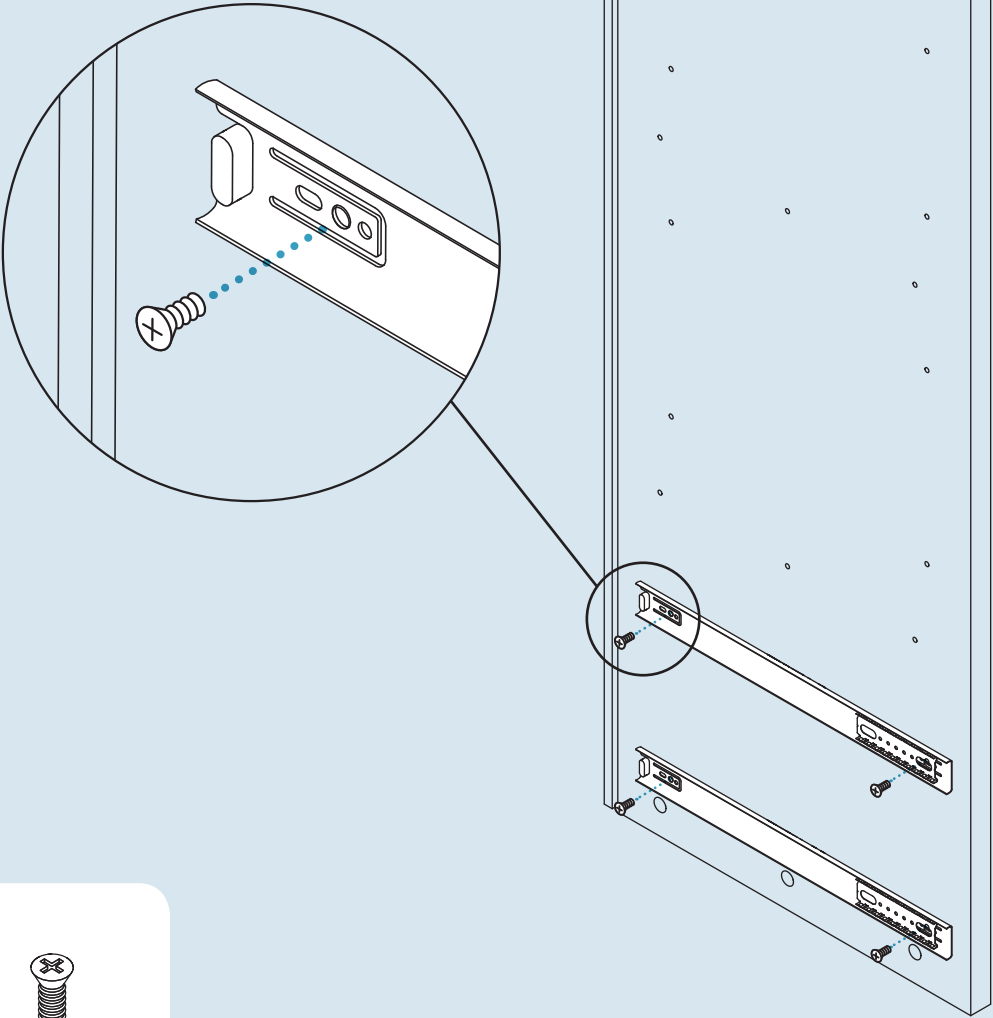

PT. 1023 x 8

Step 04

BEGIN ASSEMBLING CASE.

Attach partition panels to left side panel as shown using the provided hardware. Be sure to align grooves on partition panels and side panel. Refer to page 3 on how to use the cam lock system.

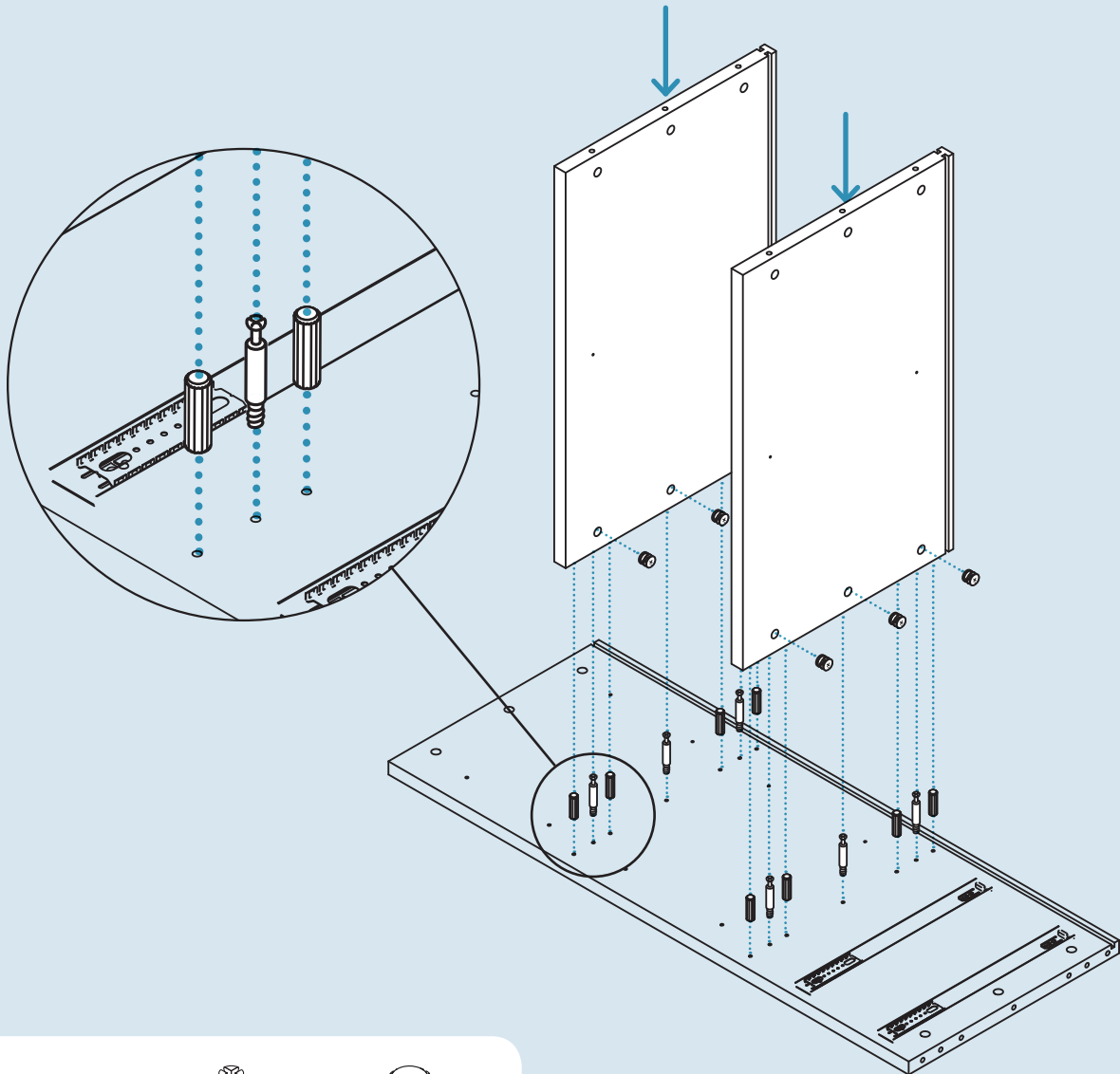

PT. 5001 x 6



PT. 5002 x 6



PT. 5005 x 8

Step 05

ATTACH RIGHT SIDE PANEL.

Slide back panel into place as shown. Attach right side panel as shown using the provided hardware. Refer to page 3 on how to use the cam lock system.

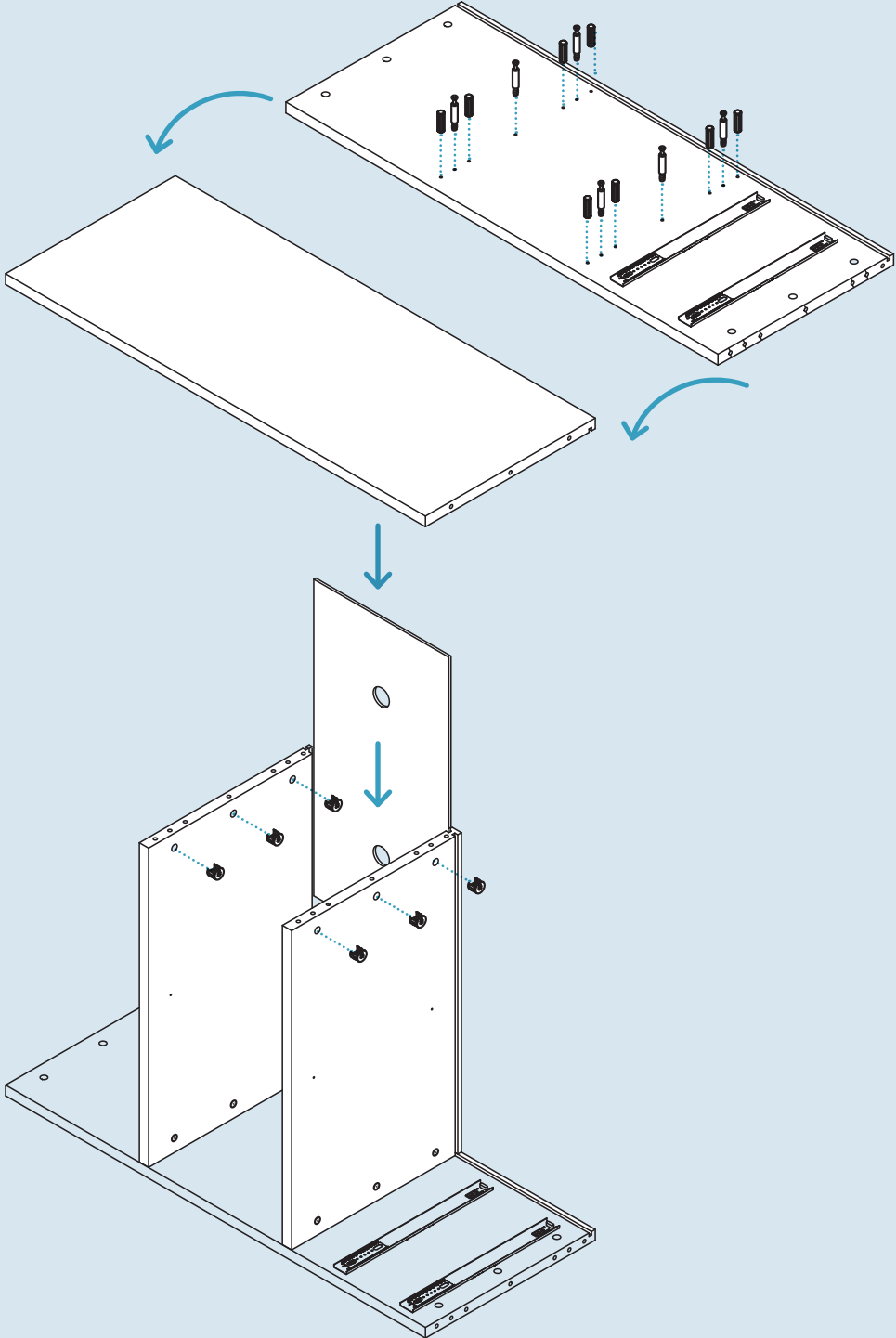

PT. 5005 x 8



PT. 5002 x 6



PT. 5001 x 6

Step 06

INSERT REMAINING BACK PANELS.

Add rubber grommets to each back panel as shown. Insert back panels into grooves in case.

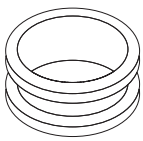
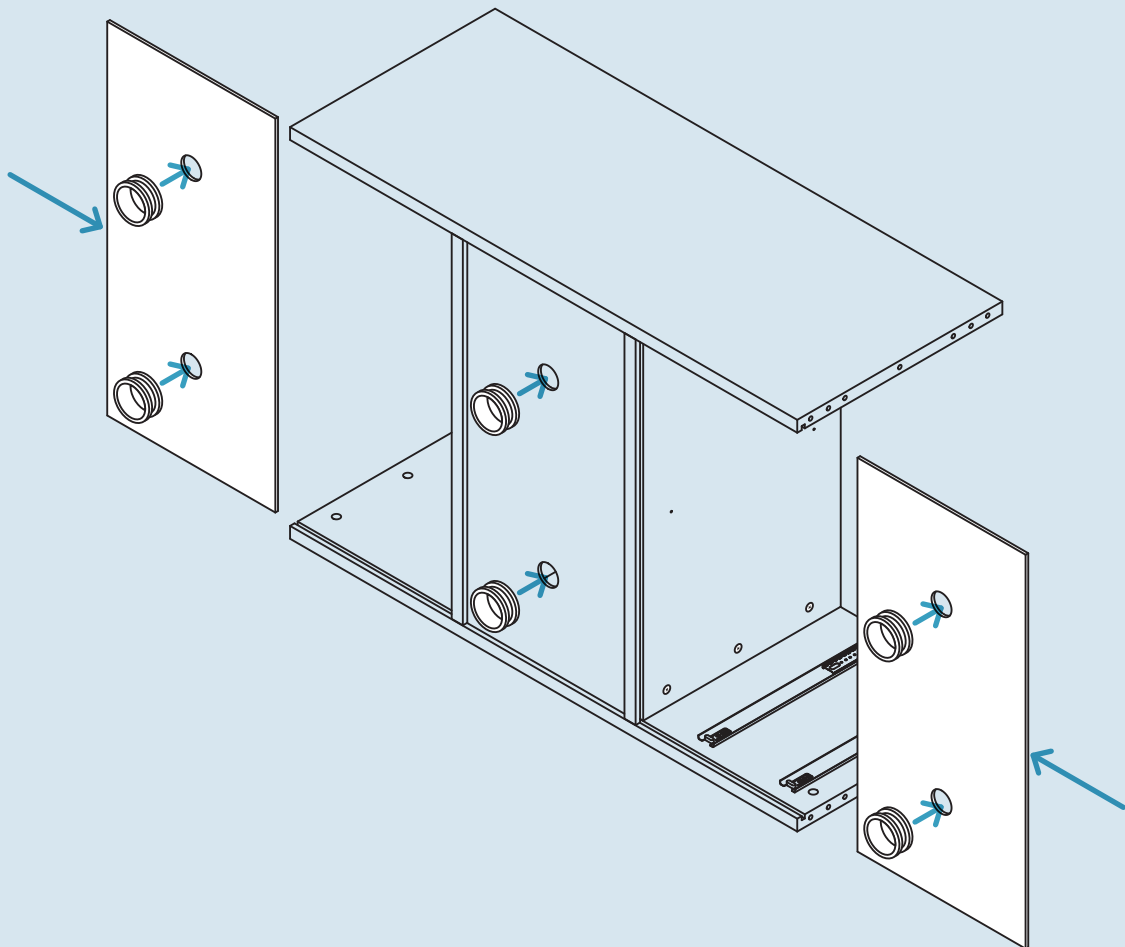

PT. 8018 x 6

Step 7

FINISH ASSEMBLING CASE.

Finish assembling the case by attaching the top and bottom panels as shown using the provided hardware. Refer to page 3 on how to use the cam lock system.

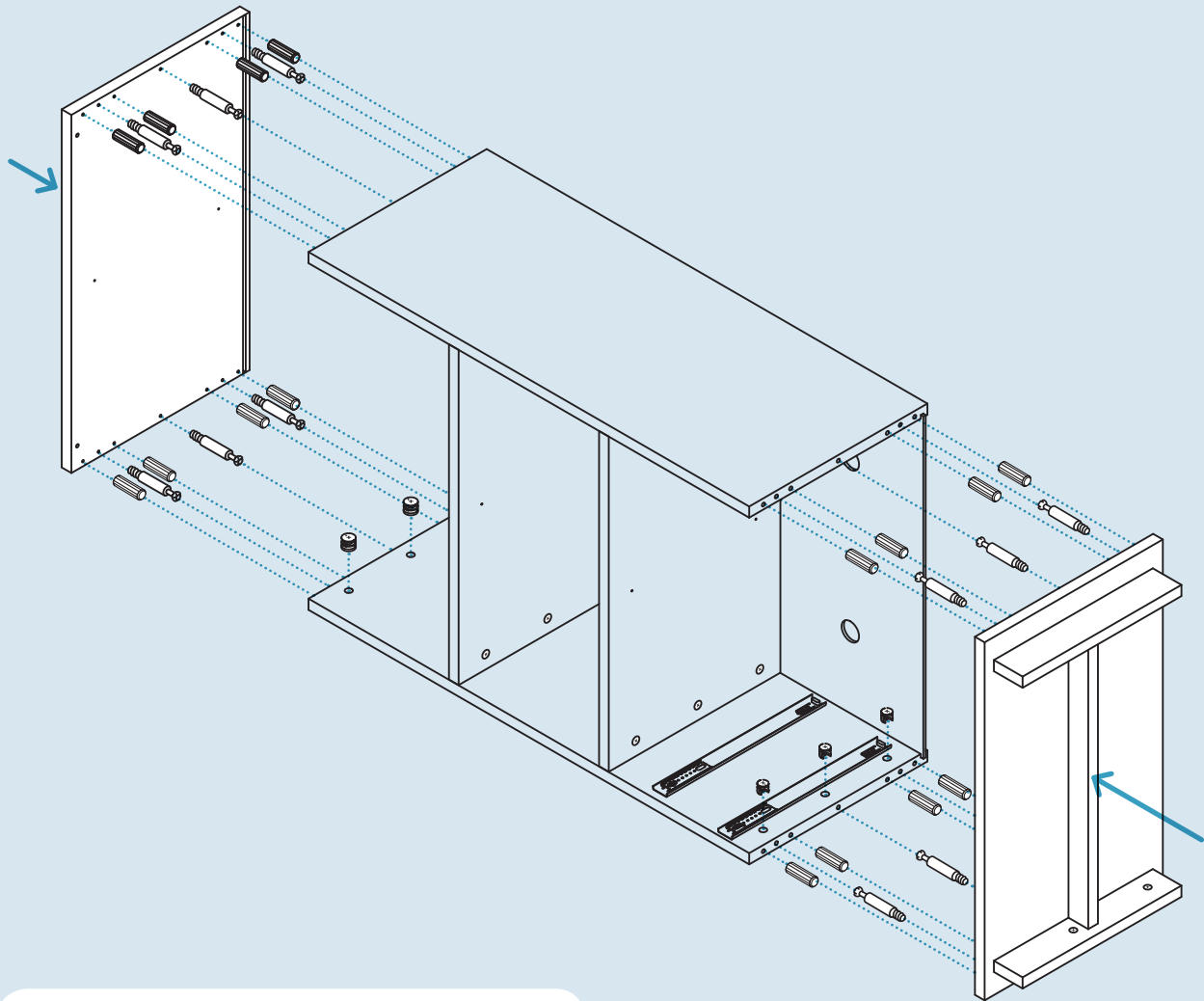

PT. 5001 x 12



PT. 5002 x 12



PT. 5005 x 16

Step 08

INSTALL DRAWERS.

To install the drawers extend drawer slides out from case, align with drawer slides as shown, and slide drawer in. Be sure to push until drawer is completely closed and engaged.

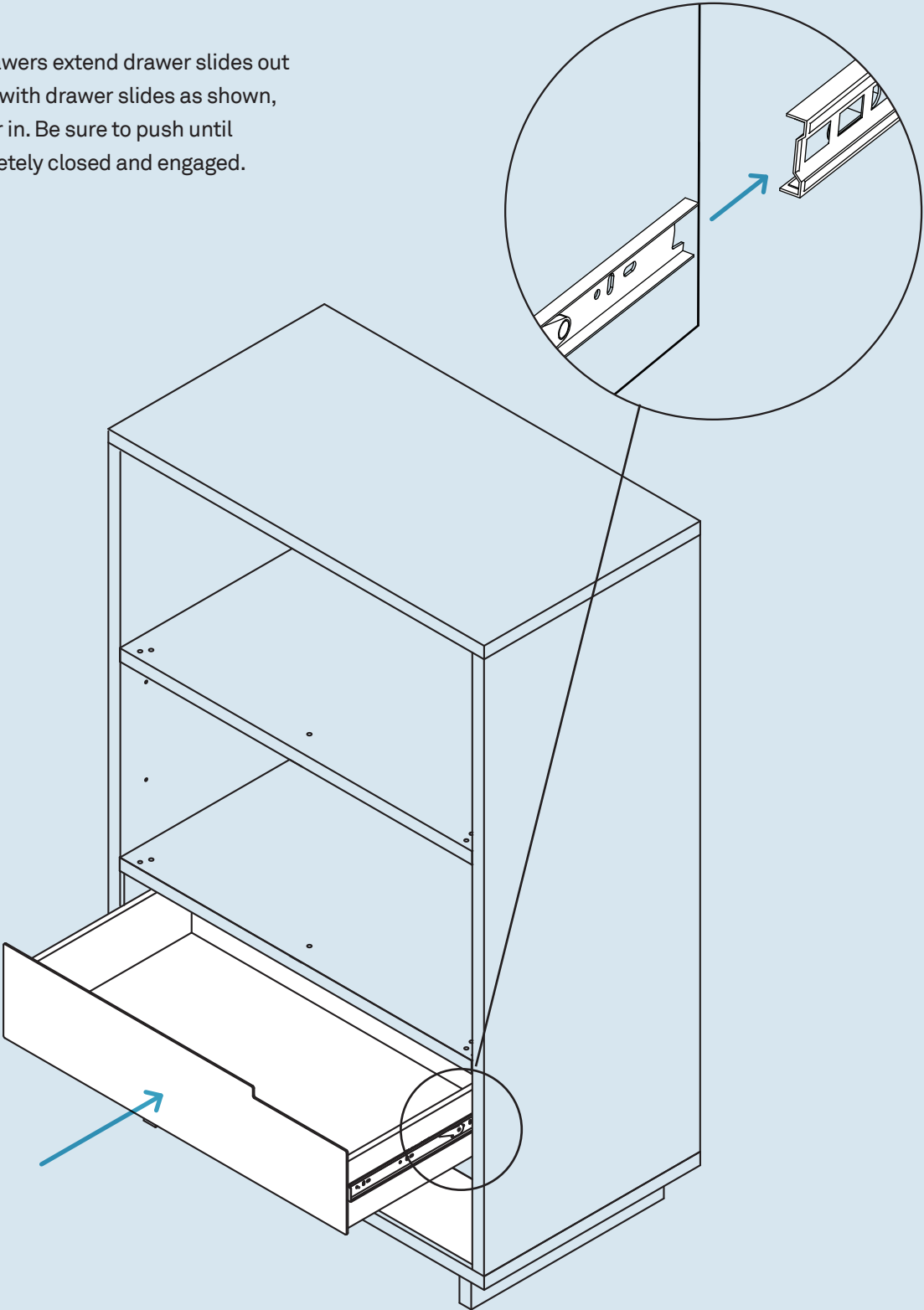

Step 09

INSERTING THE PARTITION PANELS.

Attach the metal brackets and magnet catches as shown. Align partition panel grooves with brackets and slide into place.

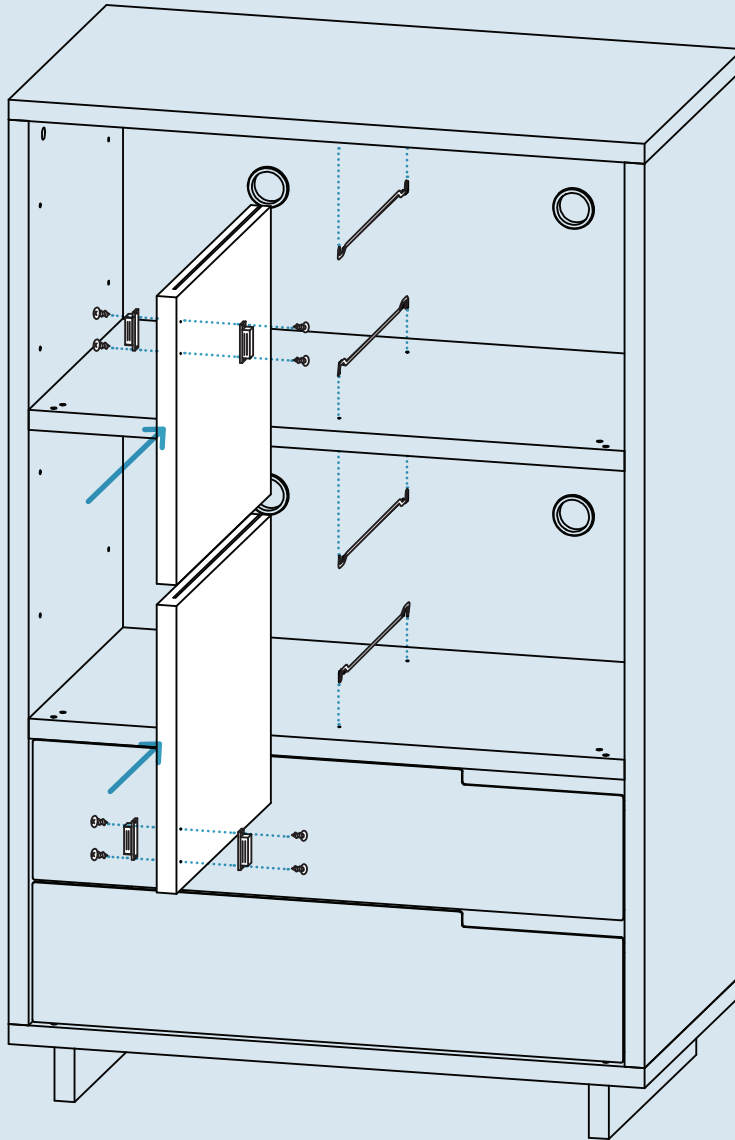

PT. 1206 x 8

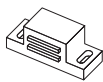

PT. 8045 x 4

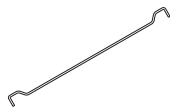

PT. 8017 x 4

Step 10

ATTACH DOOR BUMPERS.

Attach the door bumpers as shown using the provided hardware.

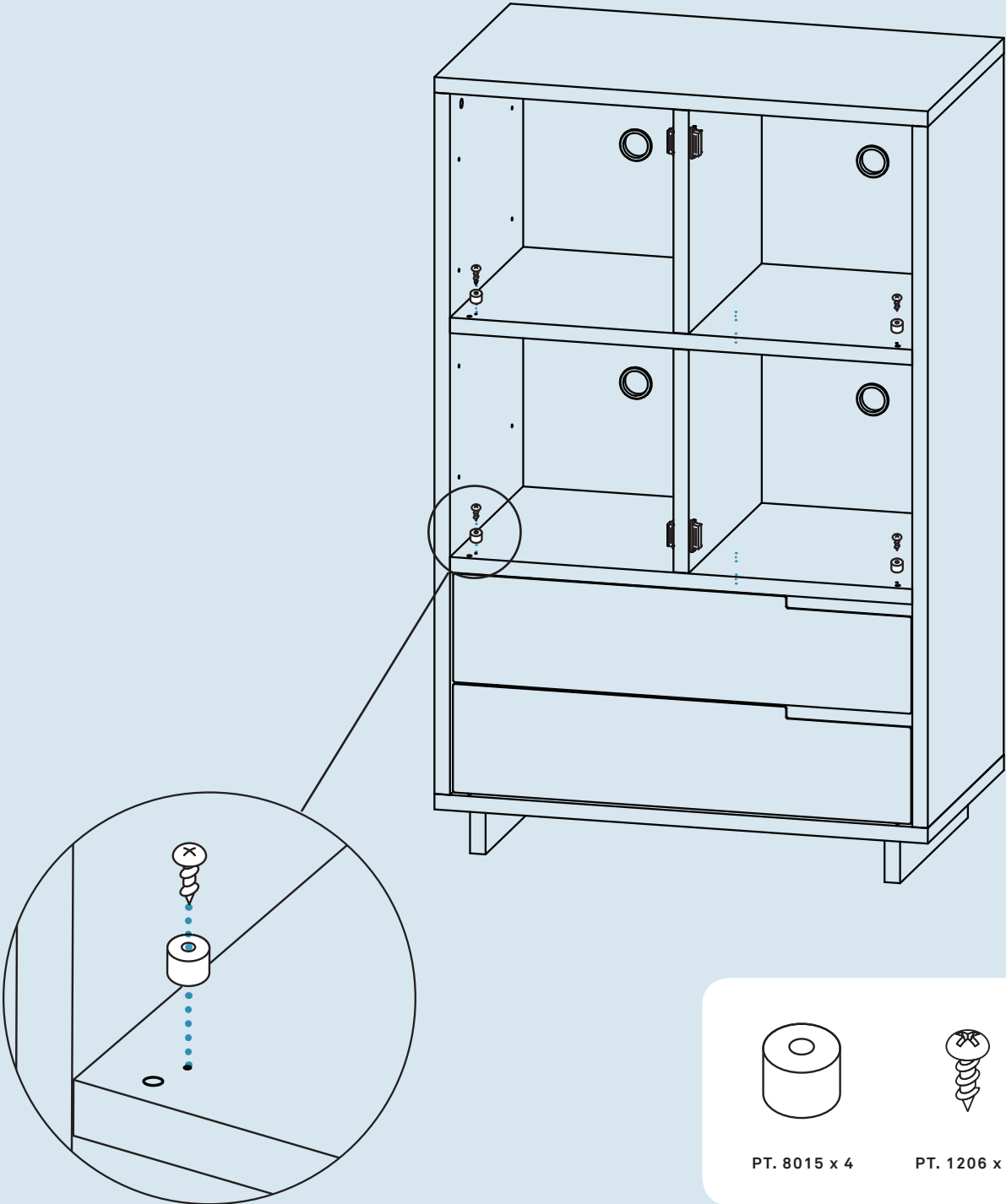

Step 11

INSTALL DOORS.

To install the doors, start by sliding the metal rod through the brackets on the back of each door. Next install doors as shown below.

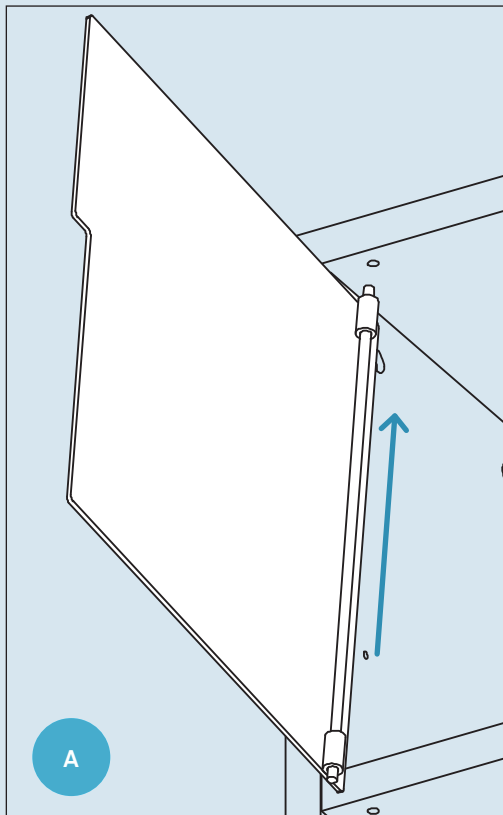
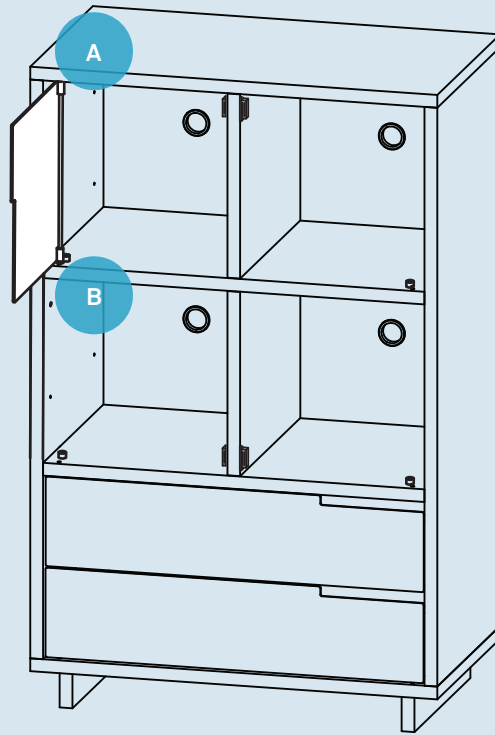

Angle door and push rod into the pre-drilled hole on the underside of the top panel.

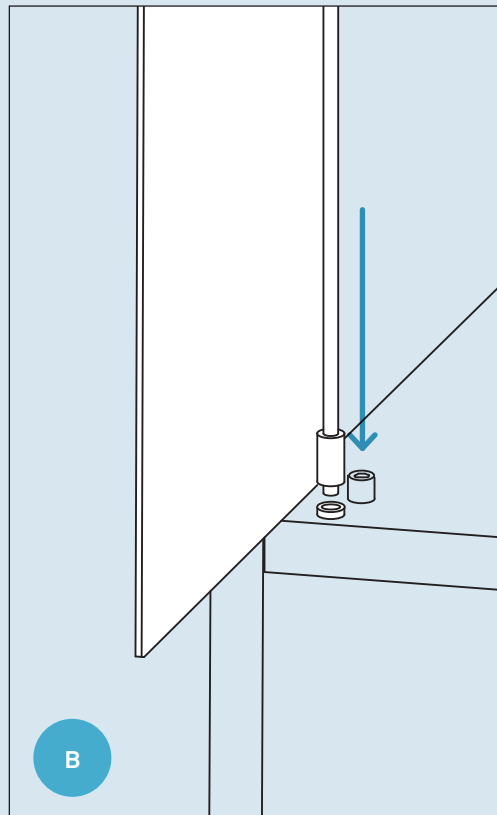

Align rod with with lower pre-drilled hole. Slide rod through plastic washer and into pre-drilled hole.



PT. 8014 X 4



PT. 8016 X 4

Step 12

ATTACH ANTI-TIP BRACKET TO THE WALL.

Install anti-tip bracket to wall stud 1-inch below case top panel height.

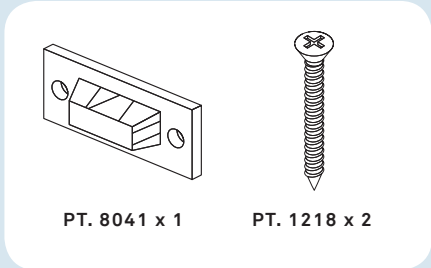
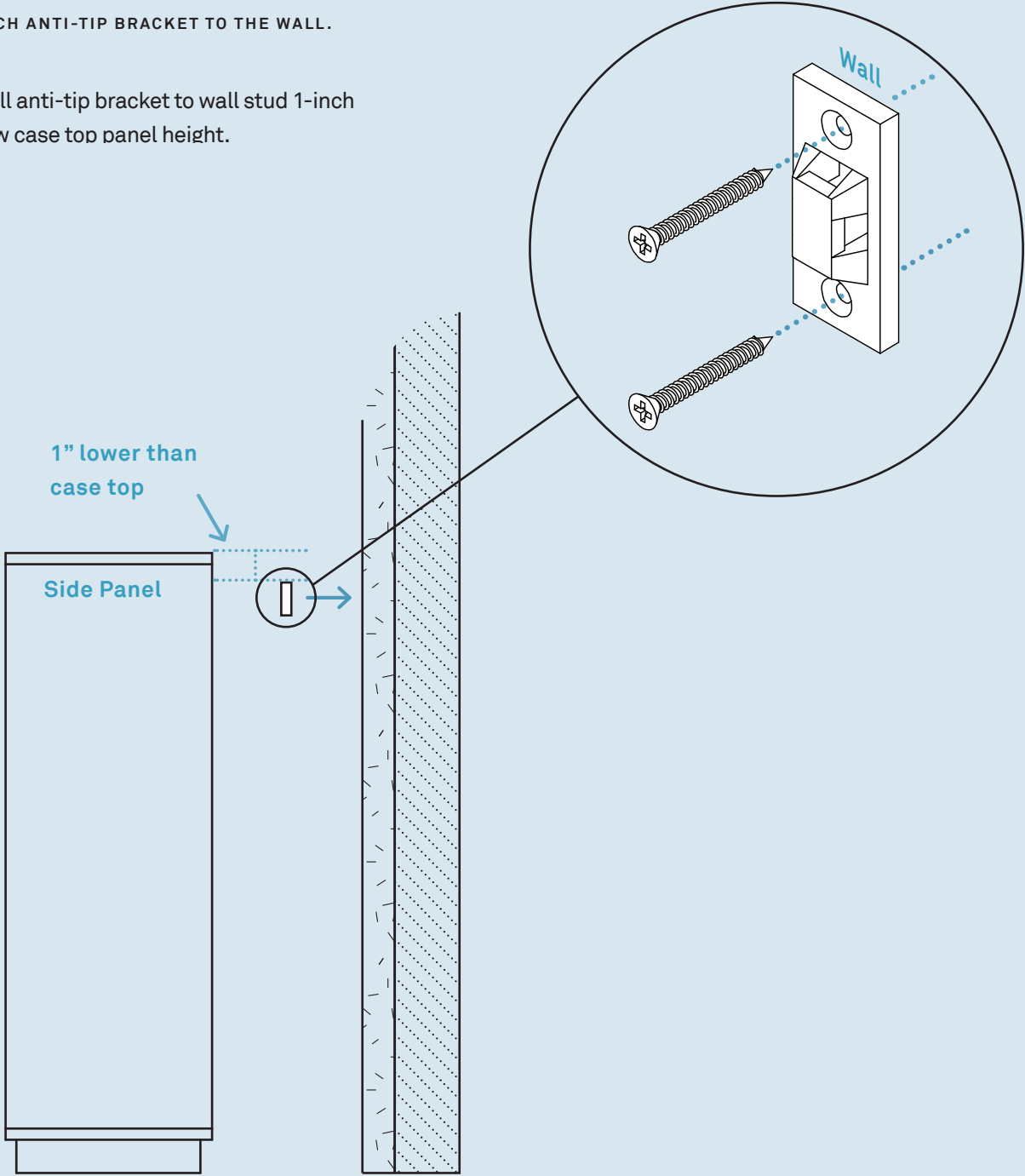

Step 13

INSTALL ANTI-TIP BRACKET TO CASE.

Bracket must be installed to top panel of case. In order to prevent damage, it is recommended that 3/32" pilot holes be drilled prior to installation.

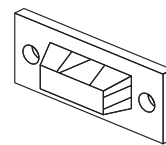
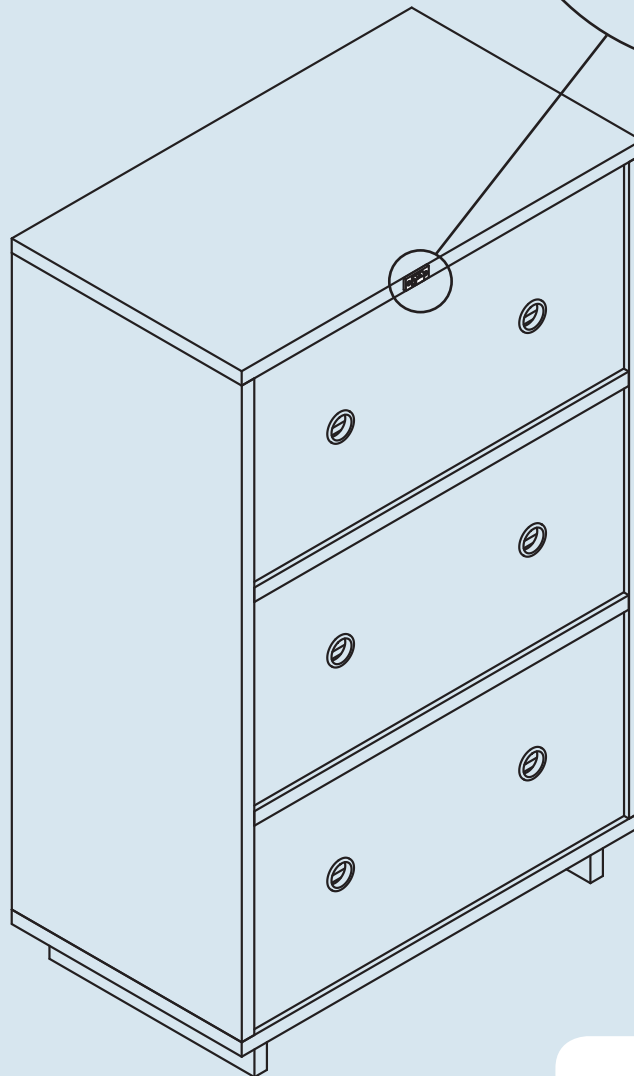
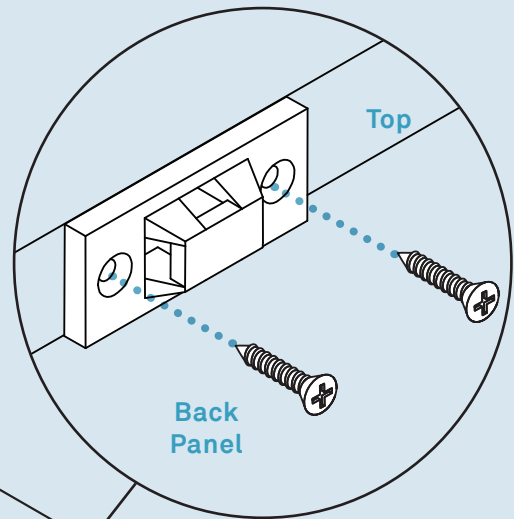

PT. 8041 x 1



PT. 1217 x 2

Step 14

SECURE THE CASE.

Install and tighten the strap prior to using the product.

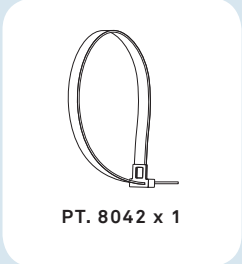
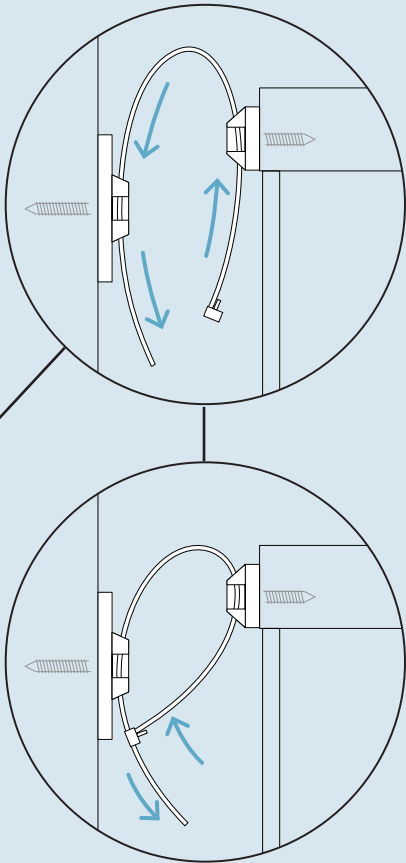
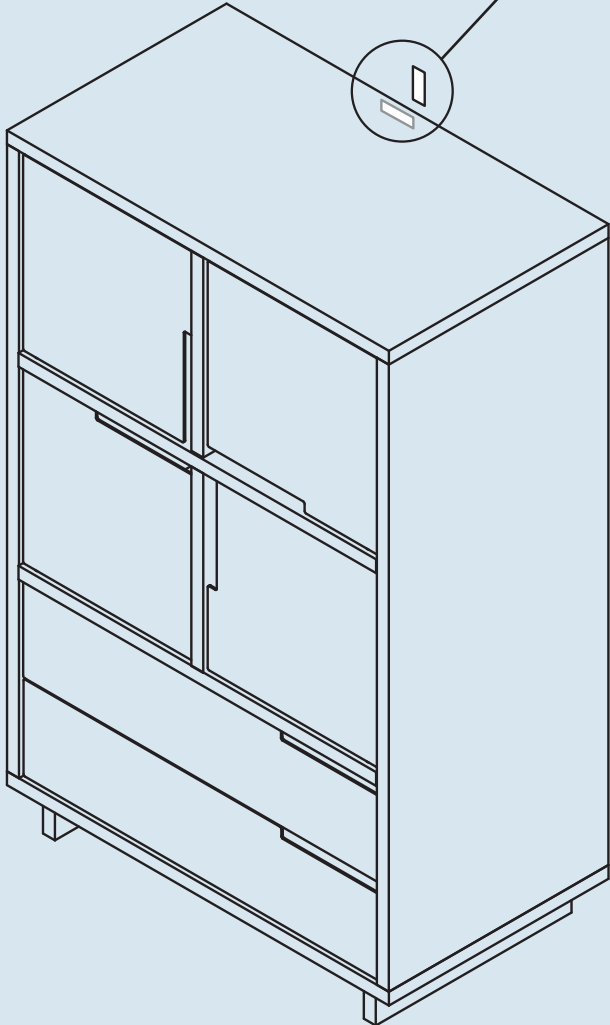

PT. 8042 x 1

Additional Information

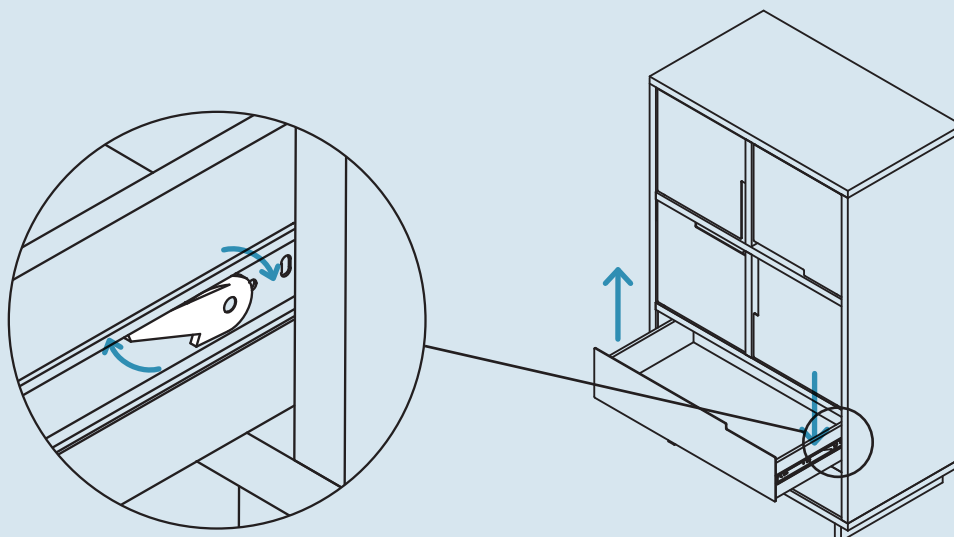

TO REMOVE DRAWERS

Pull lever up on the right side and push down on the left side of the drawer slide. With levers engaged pull drawer out.

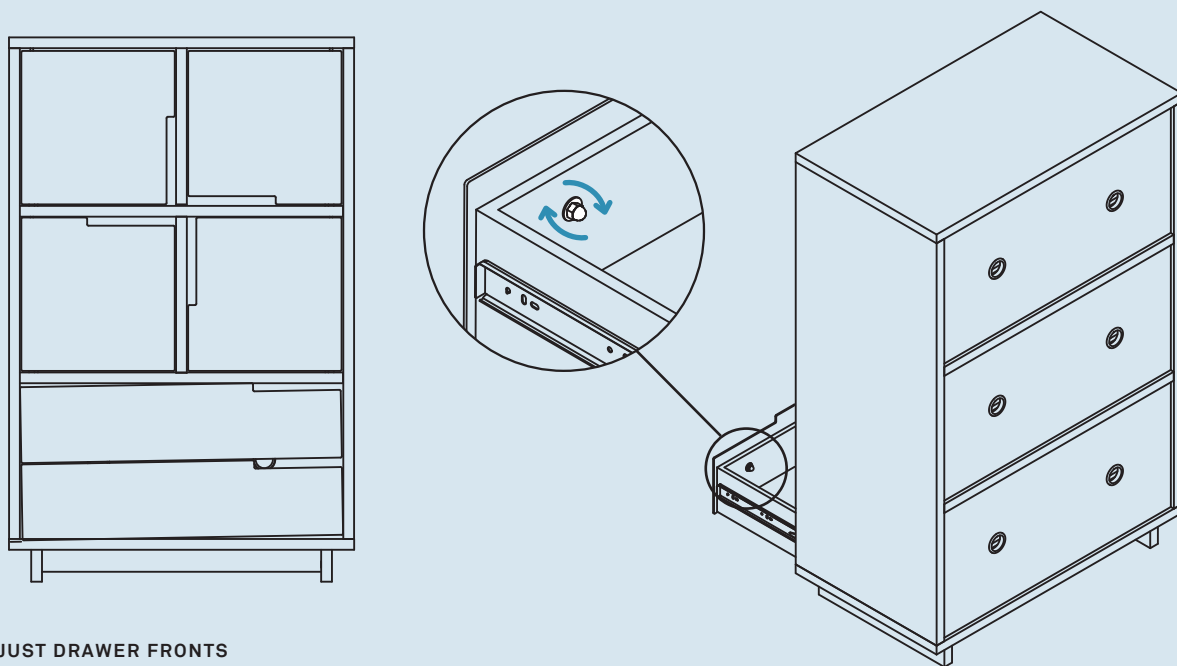

TO ADJUST DRAWER FRONTS

Loosen the acorn nuts, adjust drawer front, re-tighten acorn nuts.

CLEAN

Clean with a slightly damp, soft cloth. To remove dirt and fingerprints, use a quality cleaner formulate for wood furniture. Wipe completely dry with a soft cloth in the direction of the wood grain.

